

AQUA SENTRY

Operating Manual Multi-Probe Oil/Grease Alarm (Mains) Type PP/CAEx

Installation, Operation & Maintenance



Product Supplied

The marked product code and firmware configuration below indicate the specific configuration of the alarm supplied.

Table 1 shows the standard products that are available. Other combinations are available on request.

Supplied	Product Code	Power Source		IN 3 Type	Relay Outputs	Wireless
		Battery	Mains			
	PP/CAEx-2-M230-1-W0	X	230V	Capacitive	1	X
	PP/CAEx-2-M230-3-W0	X	230V	Capacitive	3	X
	PP/CAEx-2-B-1-W0	✓	X	Capacitive	1	X
	PP/CAEx-2-B-3-W0	✓	X	Capacitive	3	X

Table 1: Standard products

Supplied	Firmware Config ID	Power Source		Type	High Oil Probe	Language
		Battery	Mains			
	C0013	X	✓	Oil separator alarm or Grease separator alarm	Conductivity probe IN 1	English
	C0014	✓	X	Oil separator alarm or Grease separator alarm	Conductivity probe IN 1	English
	C0019	X	✓	Oil separator alarm or Grease separator alarm	PP/DGP-1 IN 3	English
	C0020	✓	X	Oil separator alarm or Grease separator alarm	PP/DGP-1 IN 3	English

Table 2: Standard firmware configurations

Product Codes

$$\frac{\text{PP/CAEx}}{\text{①}} - \frac{2}{\text{②}} - \frac{\text{M230}}{\text{③}} - \frac{1}{\text{④}} - \frac{\text{W0}}{\text{⑤}}$$

1. PP/CAEx – Common Alarm (Hazardous area certified)
2. PCBA version:
 - 2 – V2.xx Printed Circuit Board Assembly, IN 3 = Capacitive probe.
 - 2S – V2.xx Printed Circuit Board Assembly, IN 3 = Silt probe.
3. Power source:
 - M230 – Mains powered (230V).
 - B – Battery powered.
4. Relay outputs:
 - 0 ... 4 – 0 to 4 relay outputs fitted.
5. Wireless communications:
 - W0 – No wireless.

Applicable Firmware

Firmware ID	Description	Version
PP/FMW-1124	PP/CAEx Common Alarm	V1.04 or later

Contents

- Product Supplied 2
- Product Codes..... 2
- Applicable Firmware 2
- Safety Symbols..... 5
- General Function..... 5
- General Operation..... 5
- Technical Support..... 6
- Installation 6
 - Safety Instructions 6
 - Specific Conditions for Safe Use..... 7
 - Installation Steps 7
 - Installation Diagram..... 9
 - Probe Terminals 10
 - High Oil Detection by Conductivity Probe..... 10
 - Input 1 10
 - Input 2 10
 - Input 3 10
 - High Oil or FOG Detection or by PP/DGP-1 Capacitive FOG Probe 10
 - Input 1 10
 - Input 2 10
 - Input 3 11
 - Cess Pit Using PP/GCT-4136 LR03 Level Regulator Probe..... 11
 - Input 1 11
 - Input 2 11
 - Input 3 11
 - Beacon Terminals..... 11
 - Jumper Link and DIP Switch Settings 13
- Operation 14
 - Apply Power 14
 - Startup Screens..... 14
 - Main Screen..... 14
 - Checking the Probes Manually 15
 - Test Mode 15
 - Manual Control of Outputs 16
- Technical Specifications 17

Control Panel..... 17

LED Beacon PP/BCN-1-2..... 18

PP/DGP-1 Capacitive FOG Probe Specifications..... 18

Limiting (Entity) Parameters..... 18

Accessories 20

 Probe Types..... 20

 Probe Accessories 21

 Beacon..... 21

Repair and Service 21

PP/CAEx Common Alarm UK DoC 22

PP/CAEx Common Alarm EU DoC 23

PP/DGP-1 Capacitive FOG Probe UK DoC 24

PP/DGP-1 Capacitive FOG Probe EU DoC 25

Safety Symbols



Safety instructions



Alarm is protected against shock hazard by double or reinforced insulation

General Function

The unit is designed to monitor an oil separator tank for a build-up of oil or fuel, or a grease separator for a build-up of fat, oil or grease. An alarm sounds and an LED beacon flashes when an alarm condition is detected. An LCD displays messages to indicate alarm conditions. The unit is mains powered.

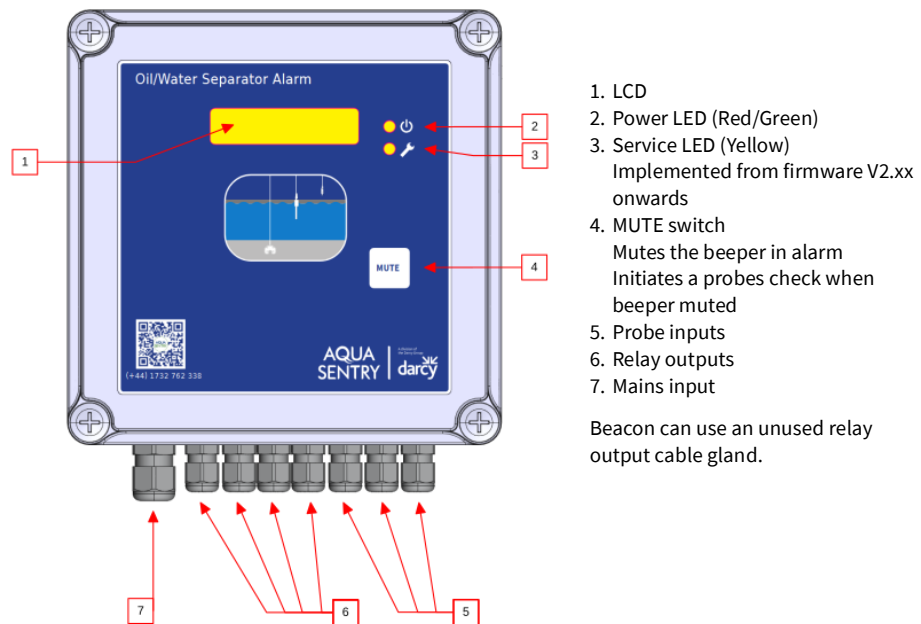

1. LCD
2. Power LED (Red/Green)
3. Service LED (Yellow)
Implemented from firmware V2.xx onwards
4. MUTE switch
Mutes the beeper in alarm
Initiates a probes check when beeper muted
5. Probe inputs
6. Relay outputs
7. Mains input

Beacon can use an unused relay output cable gland.

Figure 1: Cable glands, LCD and push button positions

General Operation

The Control Unit monitors the condition of the connected probe units by checking their condition every 30 minutes. Their current status is displayed on the LCD located on the front of the unit. If an alarm condition is detected, a warning message is displayed followed by notification of the alarm condition detected, e.g. *HAZARD ALERT* High Oil Alarm, the output relay energises, and the internal beeper is audible.

The unit then gives the option, via the display, to accept/acknowledge the alarm. On doing so, the output relay de-energises, the beeper is muted, and the display instructs the user to take the appropriate action, e.g. empty the oil/grease separator. After the oil/grease separator has been emptied and refilled with water, the control unit re-scans the probe sensors attached and presuming no alarm condition is detected, 'All Correct' will be displayed. If the push button is pressed before the oil/grease separator has been emptied, or it has been emptied but not refilled with water, then the control simply scans the probe sensor(s) and reverts to the alarm condition.

When an alarm exists, the beacon flashes continuously until the MUTE push button is pressed or the alarm clears.

Technical Support

Technical support and repairs may be obtained from:

Darcy Spillcare Manufacture
 1 Hickmans Rd
 Wallasey
 Birkenhead
 CH41 1JH
 United Kingdom
 Phone: 0800 0370 899 (UK), +44 (0) 1732 762338 (Rest of world)

Installation

Note: In all cases good, standard electrical practice should be followed and the installation must conform to the appropriate local code of practice – e.g., BS EN 60079-25 and BS 7671:2018+A3:2024 in the UK. The installation must be such that the intrinsic safety is not compromised by: - exposure to risk of mechanical damage, unauthorised modification or interference, exposure to moisture, dust and foreign bodies, excessive heat, invasion of intrinsically safe circuit by other electrical equipment or circuitry.

Any deviation from this could invalidate the certification warranty and render the unit unsafe for its intended use. Please contact Aquasentry for any advice on 01732 441016.

The unit must be installed using a peak or similar cover to protect from direct sunlight.

Safety Instructions

- ⚠ Installation should only be performed by a skilled, competent person according to IEC 60079-14 and local wiring regulations.
- ⚠ The type of cable to be used must suit the environment and the size of cable must be of a suitable size and current carrying capacity to suit the length of run and power consumption of the alarm, as per local wiring regulations. The cable must be protected by a suitable circuit breaker as per local wiring regulations. A 6A MCB and a minimum cable size of 1.0mm² is recommended. The control unit should be connected as a permanently wired installation.
- ⚠ Only a round section mains cable between 5mm and 10mm should be used to ensure a good seal is maintained in the M16 cable gland.
- ⚠ If extending the probe cables, only a round section cable between 3mm and 6.5mm should be used to ensure a good seal is maintained in the M12 cable glands.
- ⚠ The alarm is certified ATEX/UKEX/IECEx as Associated Apparatus and must only be installed in the safe area.
- ⚠ The conductivity probe and high level probe are Simple Apparatus and can be installed in the hazardous area.
- ⚠ The PP/DGP-1 Capacitive FOG Probe is ATEX/UKEX/IECEx certified and can be installed in the hazardous area.
- ⚠ Care must be taken that there are no loose wire strands which could come into contact with adjacent terminals. This is especially important between L and N terminals of J9. The use of bootlace ferrules is recommended to reduce the risk.
- ⚠ Cable glands supplied with the alarm are IP66 or better. Only use cable glands with at least an IP66 rating if replacing them for any reason.

- ⚠ Only use the mounting points shown in Figure 4. Do not drill holes in the enclosure or otherwise modify it as this would affect the IP65 rating and may allow water and/or moisture to enter the enclosure, affecting the correct function of the alarm and/or electrical safety, resulting in a potential electric shock hazard. It would also invalidate the ATEX/UKEX/IECEX certification.
- ⚠ Mounting hardware used to secure the control unit to a wall or other mounting point must be suitably rated to hold the weight.
- ⚠ The voltages used on all the relay output contacts must be similar, i.e. do not mix low voltage (ELV) and high voltage (LV).
- ⚠ Maximum allowed voltage, current and power for relay contacts is determined by EN 60079-11:2012 Cl, 6.3.14. See Technical Specifications.
- ⚠ The product has been certified to use only PP/BCN-1-2 beacon on the beacon output, J13. Only use this type of beacon. Do not attach any other device to this output.
- ⚠ The control panel may not function correctly if it is not used in accordance with the instructions in this manual.

Specific Conditions for Safe Use

1. The relay outputs “OUT1”, “OUT2”, “OUT3” and “OUT4”, individually must not switch more than the following root-mean-square electrical values for resistive loads; 250 Volts, 5 Amperes, or 100 Volt-Amperes.
2. Only the Darcy “PP/BCN-1-2 LED Beacon” shall be connected at connector marked “BEACON + -”.

Installation Steps

1. Choose a mounting position that will not be exposed to direct sunlight or use a peak or similar cover to prevent direct sunlight exposure.
2. Use the mounting points provided on the enclosure to mount in the position required. See Figure 4 for mounting points and dimensions.
3. The alarm is supplied fitted with IP66 (or better) blanking plugs to protect against water ingress if installed prior to wiring. At the time of wiring, replace with the supplied IP66 (or better) cable glands as required for the installation. Ensure all the unused holes are fitted with blanking plugs to prevent water ingress.
4. For an oil separator:
 - a. For a float switch probe, hang the probe in the tank at the position which an alarm should occur.
 - b. For a conductivity probe, immerse the probe in water. The depth of oil build up that will cause an alarm is chosen by the depth of the top electrode. An alarm occurs when the top electrode is covered by oil or is exposed to air.
 - c. For a PP/DGP-1 Capacitive FOG Probe, immerse the probe in water. An alarm will occur when about the top 80% is oil or air, so a thinner oil layer can be detected by partially exposing the top of the probe to air.
 - d. Wire the float, conductivity, silt or capacitive probe cables into J1 ... J3 terminals on the PCBA inside the alarm according to Figure 2 and the wiring details in the Probe Terminals section. For a float switch probe, hang the probe in the tank at the position which an alarm should occur.
5. For a grease separator:
 - a. Immerse the PP/DGP-1 Capacitive FOG Probe in the grease separator water. An alarm will occur when about the top 80% is oil or air, so a thinner fat, oil or grease layer can be detected by partially exposing the top of the probe to air.

- b. Wire the PP/DGP-1 Capacitive FOG Probe cable into J3 terminals on the PCBA inside the alarm according to the wiring details in the Probe Terminals section.
6. If supplied, wire the beacon into J13 according to Table 10. Only use beacon type PP/BCN-1-2.
7. Ensure the jumper link J10 and SW1, DIP switch 4 are set according to the alarm configuration supplied. See Table 2 and Figure 5.
8. Ensure any unused probe inputs are disabled so they don't cause an alarm. See Figure 5.
9. Wire a cable supplying 230VAC $\pm 10\%$ 50/60Hz to J9 on the PCBA inside the alarm.
 - a. A switch (to IEC 60947-3) or circuit-breaker (to IEC 60947-2) must be included in the installation.
 - b. It must be suitably located and easily reached.
 - c. It must be marked as the disconnecting device for the alarm.
10. Ensure the mains supply cable gland is tightened with a spanner to ensure that it anchors the mains cable to prevent it being pulled from the J9 terminal block.

Screw the lid back onto the enclosure base and ensure the 4 screws are tightened enough, but not over tight (1.0 Nm), that the rubber seal is compressed to maintain the IP65 seal.

Installation Diagram

The installation diagram shows probes typically used for an oil separator. Refer to Probe Types for other types.

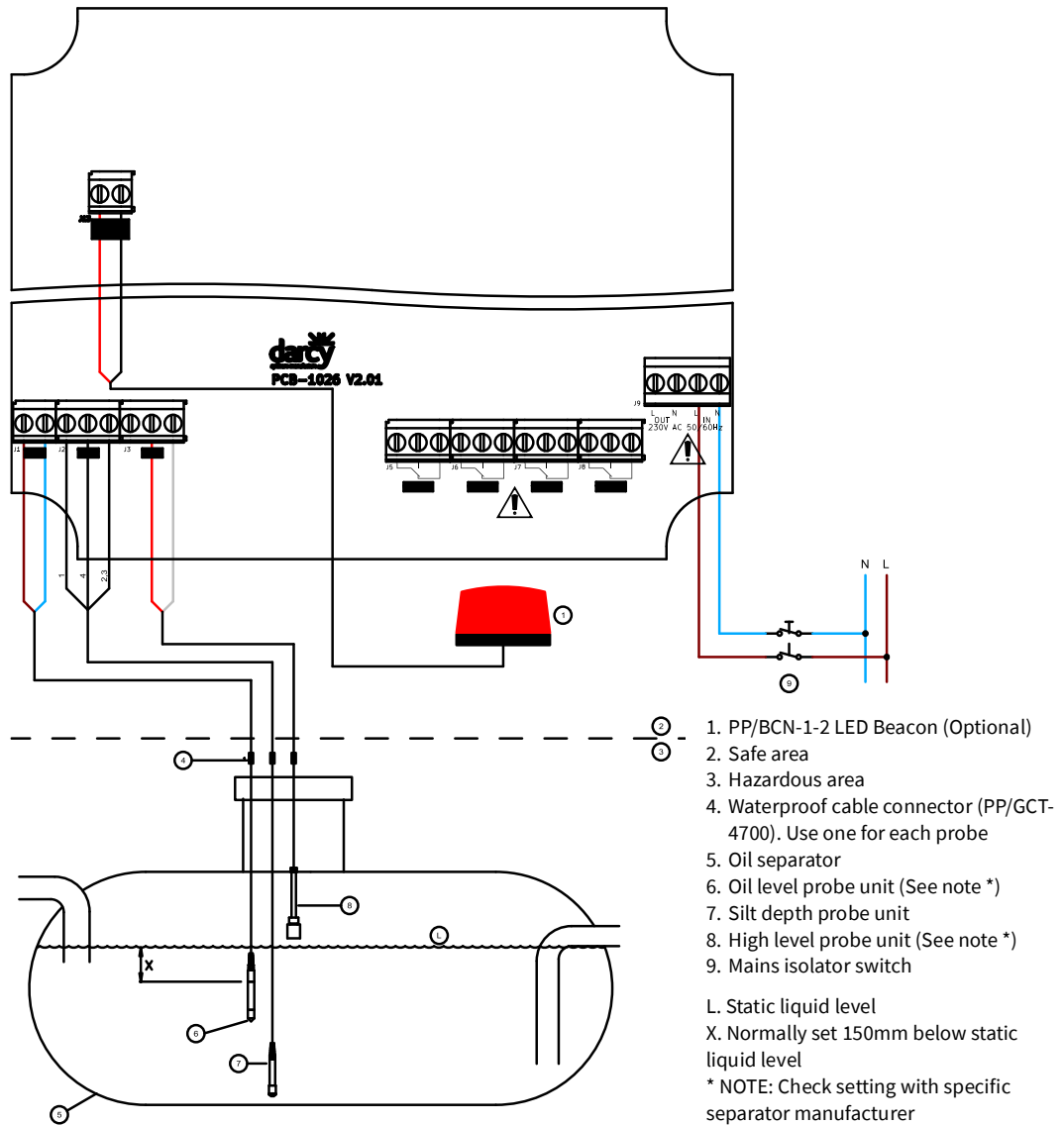

Figure 2: Typical installation for an oil separator alarm: Wiring probes, beacon and mains supply

Probe Terminals

There are two different sets of wiring tables depending on whether the alarm panel supplied is configured for High Oil detection to use a conductivity probe or a PP/DGP-1 Capacitive FOG Probe. See Table 2 for the supplied configuration.

Each of the 3 probe inputs only supports some probe models, as below.

Refer to Figure 5 for DIP switch settings to enable/disable probes that are in use.

High Oil Detection by Conductivity Probe

For alarm panels that have been supplied configured to use a conductivity probe for High Oil detection, wire the probes as follows:

Input 1

Probe Type	J1-1	J1-2
PP/14200 – 38mm Conductivity Probe PP/14201 – 25mm Conductivity Probe PP/14205 – 12mm Conductivity Probe	Brown	Blue
PP/14000 – High Oil Float Switch Probe	Red	Black

Table 3: Input 1 (J1) High Oil probe cable connections and supported probe models

Input 2

Probe Type	J2-1	J2-2	J2-3
PP/PROBE/SILT-1 – Silt Probe (Wire 5 is optional earth wire)	Wire 1	Wire 4	Wires 2 and 3
PP/14220 – Silt Probe	Brown	Green/Yellow	Blue

Table 4: Input 2 (J2) Silt probe cable connections and supported probe models

Input 3

Probe Type	J3-1	J3-2	J3-3
PP/PROBE/HLQD-1 – High Liquid Float Switch Probe		Red	White

Table 5: Input 3 (J3) High Liquid probe cable connections and supported probe models

High Oil or FOG Detection or by PP/DGP-1 Capacitive FOG Probe

For alarm panels that have been supplied configured to use a PP/DGP-1 Capacitive FOG probe for High Oil or FOG detection, wire the probes as follows:

Input 1

Probe Type	J1-1	J1-2
PP/PROBE/HLQD-1 – High Liquid Float Switch Probe	Red	White

Table 6: Input 1 (J1) High Liquid probe cable connections and supported probe models

Input 2

Probe Type	J2-1	J2-2	J2-3
PP/PROBE/SILT-1 – Silt Probe (Wire 5 is optional earth wire)	Wire 1	Wire 4	Wires 2 and 3
PP/14220 – Silt Probe	Brown	Green/Yellow	Blue

Table 7: Input 2 (J2) silt probe cable connections and supported probe models

Input 3

Probe Type	J3-1	J3-2	J3-3
PP/14000 – High Oil Float Switch Probe		Red	Black
PP/DGP-1 – Capacitive FOG Probe	Brown	Green/Yellow	Blue

Table 8: Input 3 (J3) High Oil / FOG probe cable connections and supported probe models

Cess Pit Using PP/GCT-4136 LR03 Level Regulator Probe

For alarm panels that have been supplied configured as C0013 or C0014, according to Table 2, and are to be used in a cess pit application, wire the probe as follows:

Input 1

This probe input is not used in a cess pit application.

Input 2

This probe input is not used in a cess pit application.

Input 3

Probe Type	J3-1	J3-2	J3-3
PP/GCT-4136 – LR03Level Regulator Float Switch Probe This probe is NOT Simple Apparatus! Do NOT use in an Ex-application, such as an oil separator. Only intended for use in a non-Ex application, such as a cess pit.		Brown	Blue

Table 9: Input 3 (J3) LR03 Level Regulator probe cable connections

Beacon Terminals

J13 Terminal	Connect To
+	Beacon positive terminal (Red wire)
-	Beacon negative terminal (Black wire)

Table 10: Beacon cable connection details (J13)

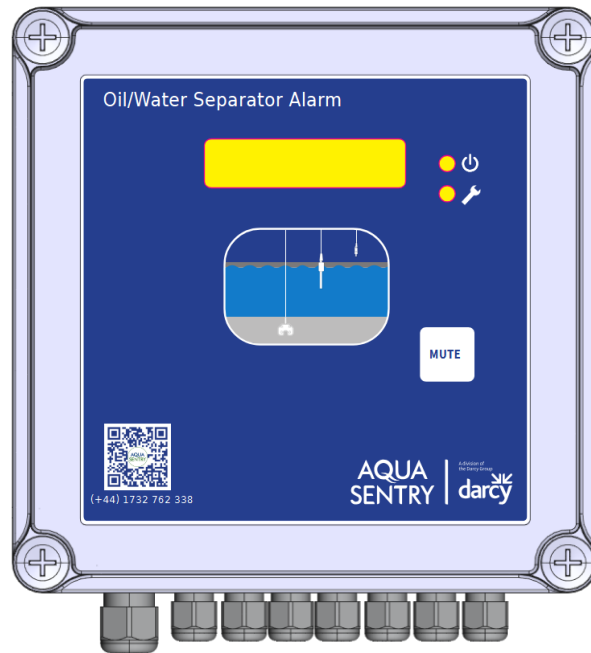

Figure 3: External view of Oil/Water Separator Alarm (Grease Alarm similar)

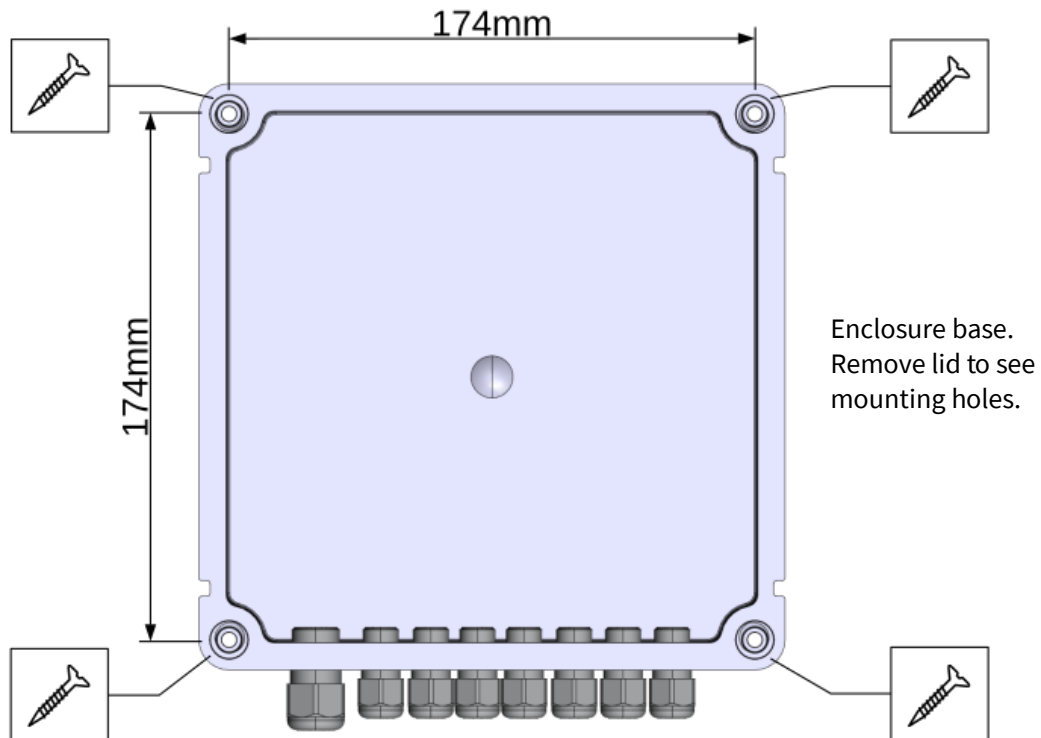

Figure 4: Enclosure mounting hole positions

Jumper Link and DIP Switch Settings

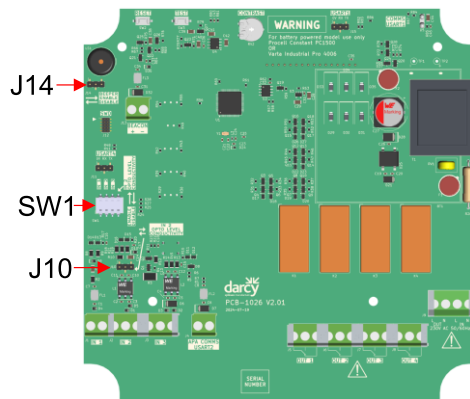

Figure 5: Jumper Link and DIP Switch Settings

NOTE: Power off and on or reset for DIP switch changes to take effect once changes are made!

SW1 DIP Switch	Probe Input	Enable / Disable
1	IN 1 (J1)	Enable Probe (ON)
		Disable Probe (OFF)
2	IN 2 (J2)	Enable Probe (ON)
		Disable Probe (OFF)
3	IN 3 (J3)	Enable Probe (ON)
		Disable Probe (OFF)
4	OFF = Oil Separator ON = Grease Separator	

Table 11: SW1 - Probe Enable and Mode Select

Always set J10 to the position shown	
--------------------------------------	--

Table 12: J10 Setting

Beeper Disabled	
Beeper Enabled	

Table 13: J14 - Beeper Enable/Disable

Operation

Apply Power

The power LED will light green when mains power is applied. It will flash red when an alarm occurs.

Startup Screens

The first screen shown after power up or reset gives the firmware ID, version and build date. The details shown below may differ from that programmed into the unit.

```
FMW-1124 RV1.03
2025-06-13 14:02
```

The second screen shown a few seconds later shows the Git commit ID, the configuration ID and revision programmed into the unit.

```
CID: e015bcd
CFG: C0001R0002
```

The third screen shown a few seconds later shows the manufacturer and model.

```
Darcy
Oil Separator
```

Main Screen

After the startup screens above, the alarm will begin checking the probes for alarm conditions. As standard, the probes are checked six times, eight seconds apart. This is to prevent false alarms that could possibly be caused by movement of the liquid in the tank. The bottom row shows the incrementing check number and number of total checks.

Other combinations of number of probe checks and check interval can be factory configured before delivery of the alarm.

```
Checking Sensors
1 / 6
```

On completion of all the checks, any alarms are displayed or "All Correct" if no alarms exist.

```
All Correct
```

If alarms exist, these messages are shown cyclically, about two seconds apart. Only the alarms that exist are displayed.

```
*HAZARD ALERT*
  High Oil
```

```
*HAZARD ALERT*
  Silt
```

```
*HAZARD ALERT*
  High Liquid
```

```
Call Darcy
01732 441022
```

For the Grease Alarm, the following is shown instead of High Oil, High Liquid or Silt.

```
*HAZARD ALERT*
Grease Build-up
```

Checking the Probes Manually

The probes can be checked at any time by simply pressing the MUTE switch.

Test Mode

Test mode can be used during installation to show the instantaneous state of all the probes. Once powered up, one of the following methods can be used to enter test mode.

- If the unit's lid is secured in place so no access to the internal board is possible without removing the lid, press and hold the MUTE switch on the front of the unit for about 5 seconds until the LCD shows "TEST MODE", then release the switch.
- With the lid removed and the board inside accessible, press and release the TEST switch on the board inside the unit.

To exit test mode, simply press the reset switch on the board inside the unit **without** pressing the MUTE switch on the front of the unit.

If no action is taken, normal operation will resume when the MUTE switch has not been pressed for 10 minutes to prevent the unit being left in test mode and to resume normal alarm function.

- The unit will reset after 10 minutes to ensure it is not accidentally left in test mode.
- Probes that have been disabled by the DIP switches on the board are shown with a '-' symbol.
- When enabled, probes show a '1' or '0' for alarm or normal, respectively.
- Battery voltage only applies to the battery variant and can be ignored for this mains powered variant.

A typical screen layout in test mode is shown below.

```
I 000 BAT=0.00V
0 00000 DIP=1000
```

Top row:

- I 000 – Current state of probe inputs, updated every second. A '0' indicates the probe is in the normal state, and a '1' indicates the probe is in alarm. A '-' indicates the probe is disabled.
- BAT=0.00V – Battery voltage. Ignore for this mains powered variant.

Bottom row:

- O 00000 – All five outputs are controlled manually to set the states of the four relay outputs and the beacon.
- DIP=1000 – The current state of the DIP switches, updated every second.

Manual Control of Outputs

The outputs can be manually controlled using the MUTE switch on the front panel.

A flashing block cursor highlights the output that will be activated/deactivated. Briefly pressing the MUTE switch moves the cursor to the next output, wrapping back to the first output after the last.

Pressing and holding the MUTE switch for about a second toggles the state of the selected output between enabled and disabled.

Technical Specifications

Control Panel

Model	Common Alarm PP/CAEx	
Enclosure	Dimensions: 194mm (W) x 194mm (H) x 61.5mm (D) Ingress Protection: IP65 Material: ABS (base), ABS (lid) Lid Screws: Torque: 1.0 Nm, Size: PH 3	
Operating Environment	Operating temperature: -20°C ... +50°C (ambient temperature) Do not allow direct exposure to sunlight Relative humidity: 100% Altitude: < 2,000m Pollution degree: 2 Overvoltage category: CAT II Intended for use indoors or outdoors, and in wet locations	
Mains Supply Voltage	230VAC ±10% 50/60Hz The internal fuses are not replaceable	
Mains Power Consumption	1.5W, 2.3VA, 0.01A, cos φ = 0.65	Beacon on continuously (not flashing)
Electrical Safety	IEC/EN 61010-1:2010+A1:2019, Class II, CAT II	
Galvanic isolation J9 to J1 ... J3	Safe electrical isolation acc. to EN 60079-11, voltage peak value 358V	
Max probe cable length	200m (less if values in Table 14 would be exceeded)	
Inputs	<p>Oil separator high oil detection by conductivity probe IN 1: Conductivity probe IN 2: Silt probe IN 3: High level float switch probe with volt-free contacts</p> <p>Oil separator high oil detection by PP/DGP-1 Capacitive FOG Probe IN 1: High level float switch with volt-free contacts IN 2: Silt probe IN 3: PP/DGP-1 Capacitive FOG Probe</p> <p>Grease separator IN 1: Conductivity probe or High level float switch with volt-free contacts IN 2: Silt probe IN 3: PP/DGP-1 Capacitive FOG Probe</p>	
Relay Outputs	Up to 4 x bistable relays, volt-free SPDT contacts Maximum allowed voltage, current and power is determined by EN 60079-11:2012 Cl, 6.3.14 to be 5A, 250V AC / 30V DC, 100VA. Do not exceed.	
Beacon Output	Output suited for use with PP/BCN-1-2 LED beacon. Flashes on alarm condition.	
Audible Alarm	Internal beeper sounds intermittently on alarm condition. Can be muted by pressing a key on front panel. Can be disabled with jumper link J14.	
Keypad	Front-panel MUTE switch, internal RESET switch, and internal TEST switch.	
Display	16 x 2 character LCD Red/Green power LED Yellow service LED	
Specific Marking of Explosion Protection	 II (1) G [Ex ia Ga] IIB (-20°C ≤ Ta ≤ +50°C)	

LED Beacon PP/BCN-1-2

Model	PP/BCN-1-2
Enclosure	73mm (Diameter) 48mm (Height) 11.5mm (Base mounting plate height) Ingress Protection: IP65 Material: ABS (base), PS (lens)
Operating Temperature	-20°C ... +50°C
Operating Voltage	6V
Current Consumption	35mA
Static/Flash	Flash rate and duration controlled by firmware in control panel
Lens Colour	Red
Cable Length	5m

PP/DGP-1 Capacitive FOG Probe Specifications

Model	PP/DGP-1
Enclosure	85.5mm(L) x 30mm(Dia) IP68
Material	S303, plastic
Cable	Fixed 3-core 0.5mm ² . Length 5m. Can be extended externally to 200m.
Weight	390g (including 5m cable)
Operating Temperature	0°C ... +50°C (ambient temperature) Do not allow direct exposure to sunlight
Specific Marking of Explosion Protection	 II 1 G Ex ia IIB T4 Ga (-20°C ≤ Ta ≤ +50°C)
U_i	8.2V
I_i	110mA
P_i	225mW
C_i	7.1μF
L_i	60μH

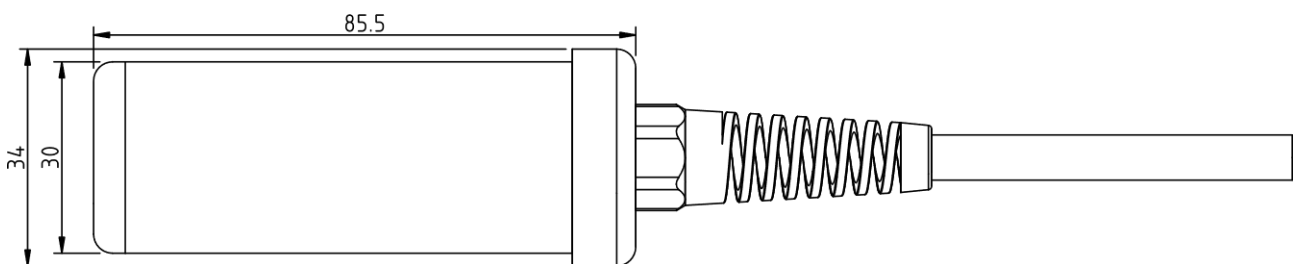

Figure 6: PP/DGP-1 Capacitive FOG Probe Dimensions

Limiting (Entity) Parameters

Parameter	Unit	IN 1 (J1)	IN 2 (J2)	IN 3 (J3)
U_o	V	8.2	8.2	8.2
I_o	mA	4.51	45.93	128.76
P_o	mW	9.27	94.17	263.96
C_o	μF	79.79	79.79	80.99
L_o	mH	6966.84	67.32	8.49

Table 14: Limiting (Entity) Parameters for J1 to J3

The limiting (entity) parameters 'L_o' and 'C_o' are valid for each input only when the bulk Inductance 'L_i' and Capacitance 'C_i' of the external circuit is matched using one of the following methods:









1. $L_i + L_{cable} < 1\%$ of L_o , and $C_i + C_{cable} < 100\%$ of C_o or;
2. $C_i + C_{cable} < 1\%$ C_o and $L_i + L_{cable} < 100\%$ of L_o or;
3. Both $L_i + L_{cable}$ and $C_i + C_{cable} < 50\%$ L_o and C_o .

In case of item 3 above, the reduced value of 'C_i' shall be $\leq 1 \mu\text{F}$ for Groups IIA, and IIB. Additionally, the values of 'C_i' and 'L_i' must also include the lumped value of any capacitance and inductance from cables connected to these inputs.

Accessories

Probe Types

These probes are suitable for use with the alarm.

Part Number	Type	Use
PP/14200 	38mm Conductivity Probe	Detection of oil build-up on the water surface in a tank
PP/14201 	25mm Conductivity Probe	Detection of oil build-up on the water surface in a tank
PP/14205 	12mm Conductivity Probe	Detection of oil build-up on the water surface in a tank
PP/14000 	High Oil Float Switch Probe (Not recommended for new installations. Use one of the above conductivity probes instead.)	Detection of oil build-up on the water surface in a tank
PP/PROBE/HLQD-1 	High Liquid Float Switch Probe	Detection of overall high liquid level in a tank
PP/PROBE/SILT-1 	Silt Probe	Detection of silt build-up in the bottom of a tank
PP/14220 	Silt Probe (Not recommended for new installations. Use PP/PROBE/SILT-1 instead.)	Detection of silt build-up in the bottom of a tank
PP/DGP-1 	Capacitive FOG Probe	Detection of oil build-up on the water surface in an oil separator tank or fat, oil or grease in a grease separator
PP/GCT-4136  NOT Simple Apparatus! Do NOT use in an Ex-application, such as an oil separator. Only intended for use in a non-Ex application, such as a cess pit.	LR03 Level Regulator NOT Simple Apparatus! Do NOT use in an Ex-application, such as an oil separator. Only intended for use in a non-Ex application, such as a cess pit.	Detection of cess level in a cess pit NOT Simple Apparatus! Do NOT use in an Ex-application, such as an oil separator. Only intended for use in a non-Ex application, such as a cess pit.

Probe Accessories

Part Number	Type	Use
PP/14103	Probe Cord Guide	
PP/14050	Probe Mounting Kit	
PP/14039	Signal Distribution Box	
PP/14006	Junction Box (Power & Probe)	
PP/GCT-4700	Waterproof Cable Connector	Extending probe cable lengths

Beacon

PP/BCN-1-2 LED beacon. The product has been certified for use with only this beacon. Only use this beacon type.

Repair and Service

For any repair or service, please contact Darcy. See section Technical Support for contact information.

Separators and alarms should be serviced and maintained in accordance with BS EN 858-2.

If cleaning is required, a damp cloth and mild detergent should be used.

PP/CAEx Common Alarm UK DoC



Darcy Common Alarm

UK DECLARATION OF CONFORMITY

This product meets all the essential safety requirements of the referenced UK Statutory Instruments.

Equipment Name and Type		Common Alarm PP/CAEx
Manufacturer		Darcy Products Ltd. Brook House Larkfield Trading Estate New Hythe Lane Larkfield Kent ME20 6GN
UK Legislation compliance		S.I. 2016/1091 Electromagnetic Compatibility Regulations 2016 S.I. 2016/1101 Electrical Equipment (Safety) Regulations 2016 S.I. 2016/1107 Equipment and Protective Systems Intended for Use in Potentially Explosive Atmospheres Regulations 2016 S.I. 2012/3032 The Restriction of the Use of Certain Hazardous Substances in Electrical and Electronic Equipment Regulations 2012
Certificate Number		ExVeritas 24UKEX1766X
Specific Marking of Explosion Protection		 II (1) G [Ex ia Ga] IIB (-20°C ≤ Ta ≤ +50°C)
Standards Used	EMC	EN IEC 61326-1:2021 (Emissions Class B)
	LVD	EN 61010-1:2010/A1:2019
	UKEX	<ul style="list-style-type: none"> • IECEx (international voluntary scheme) <ul style="list-style-type: none"> ○ IEC 60079-0:2017 Edition 7 ○ IEC 60079-11:2011 Edition 6 • ATEX (European legal directive) <ul style="list-style-type: none"> ○ EN IEC 60079-0:2018 Edition 7 ○ EN IEC 60079-11:2012 Edition 6 • UKEX (UK European legal directive) <ul style="list-style-type: none"> ○ BS EN IEC 60079-0:2018 Edition 7 ○ BS EN IEC 60079-11:2012 Edition 6
	RoHS	EN IEC 63000:2018
Serial Number and Year of Manufacture		Displayed on the side of the control unit
On behalf of the above-named company, I declare that, on the date the equipment accompanied by this declaration is placed on the market, the equipment conforms with all technical and regulatory requirements of the above listed directives and standards.		
Martin Jeffries – Quality Manager		
		DATED: 02/10/2025 Larkfield



PP/CAEx Common Alarm EU DoC



Darcy Common Alarm

EU DECLARATION OF CONFORMITY

This product meets all the essential safety requirements of the referenced EU Directives.

Equipment Name and Type		Common Alarm PP/CAEx
Manufacturer		Darcy Products Ltd. Brook House Larkfield Trading Estate New Hythe Lane Larkfield Kent ME20 6GN
Applicable European Directives:		2014/30/EU – Electromagnetic Compatibility Directive (EMC) 2014/35/EU – Low Voltage Directive (LVD) 2014/34/EU – Equipment for Potentially Explosive Atmospheres (ATEX) 2011/65/EU – Restriction of Hazardous Substances Directive (RoHS)
Certificate Number		ExVeritas 24ATEX1765X
Specific Marking of Explosion Protection		II (1) G [Ex ia Ga] IIB (-20°C ≤ Ta ≤ +50°C)
EU Harmonised Standards	EMC	EN IEC 61326-1:2013 (Emissions Class B)
	LVD	EN 61010-1:2010/A1:2019
	ATEX	<ul style="list-style-type: none"> • IECEx (international voluntary scheme) <ul style="list-style-type: none"> ○ IEC 60079-0:2017 Edition 7 ○ IEC 60079-11:2011 Edition 6 • ATEX (European legal directive) <ul style="list-style-type: none"> ○ EN IEC 60079-0:2018 Edition 7 ○ EN IEC 60079-11:2012 Edition 6 • UKEX (UK European legal directive) <ul style="list-style-type: none"> ○ BS EN IEC 60079-0:2018 Edition 7 ○ BS EN IEC 60079-11:2012 Edition 6
	RoHS	EN IEC 63000:2018
Serial Number and Year of Manufacture		Displayed on the side of the control unit
<p>On behalf of the above-named company, I declare that, on the date the equipment accompanied by this declaration is placed on the market, the equipment conforms with all technical and regulatory requirements of the above listed directives and standards.</p> <p>Martin Jeffries – Quality Manager</p>		
		<p>DATED: 02/10/2025 Larkfield</p>



PP/DGP-1 Capacitive FOG Probe UK DoC



Capacitive FOG Probe

UK DECLARATION OF CONFORMITY

This product meets all the essential safety requirements of the referenced UK Statutory Instruments.

Equipment Name and Type		PP/DGP-1 Capacitive FOG Probe
Manufacturer		Darcy Products Ltd. Brook House Larkfield Trading Estate New Hythe Lane Larkfield Kent ME20 6GN
UK Legislation compliance		S.I. 2016/1091 Electromagnetic Compatibility Regulations 2016 S.I. 2016/1107 Equipment and Protective Systems Intended for Use in Potentially Explosive Atmospheres Regulations 2016 S.I. 2012/3032 The Restriction of the Use of Certain Hazardous Substances in Electrical and Electronic Equipment Regulations 2012
Certificate Number		CML 23UKEX2128X
Specific Marking of Explosion Protection		 II 1 G Ex ia IIB T4 Ga (-20°C ≤ Ta ≤ +50°C)
Standards Used	EMC	EN IEC 61326-1:2021 (Emissions Class B)
	UKEX	<ul style="list-style-type: none"> • IECEx (international voluntary scheme) <ul style="list-style-type: none"> ○ IEC 60079-0:2017 Edition 7 ○ IEC 60079-11:2011 Edition 6 • ATEX (European legal directive) <ul style="list-style-type: none"> ○ EN IEC 60079-0:2018 Edition 7 ○ EN IEC 60079-11:2012 Edition 6 • UKEX (UK European legal directive) <ul style="list-style-type: none"> ○ BS EN IEC 60079-0:2018 Edition 7 ○ BS EN IEC 60079-11:2012 Edition 6
	RoHS	EN IEC 63000:2018
Serial Number and Year of Manufacture		Displayed on the side of the probe body or wrapped around the cable
<p>On behalf of the above-named company, I declare that, on the date the equipment accompanied by this declaration is placed on the market, the equipment conforms with all technical and regulatory requirements of the above listed directives and standards.</p> <p>Martin Jeffries – Quality Manager</p>		
		DATED: 02/10/2025 Larkfield



PP/DGP-1 Capacitive FOG Probe EU DoC



Capacitive FOG Probe

EU DECLARATION OF CONFORMITY

This product meets all the essential safety requirements of the referenced EU Directives.

Equipment Name and Type		PP/DGP-1 Capacitive FOG Probe
Manufacturer		Darcy Products Ltd. Brook House Larkfield Trading Estate New Hythe Lane Larkfield Kent ME20 6GN
Applicable European Directives:		2014/30/EU – Electromagnetic Compatibility Directive (EMC) 2014/34/EU – Equipment for Potentially Explosive Atmospheres (ATEX) 2011/65/EU – Restriction of Hazardous Substances Directive (RoHS)
Certificate Number		CML 23ATEX2127X
Specific Marking of Explosion Protection		 II 1 G Ex ia IIB T4 Ga (-20°C ≤ Ta ≤ +50°C)
EU Harmonised Standards	EMC	EN IEC 61326-1:2013 (Emissions Class B)
	ATEX	<ul style="list-style-type: none"> • IECEx (international voluntary scheme) <ul style="list-style-type: none"> ○ IEC 60079-0:2017 Edition 7 ○ IEC 60079-11:2011 Edition 6 • ATEX (European legal directive) <ul style="list-style-type: none"> ○ EN IEC 60079-0:2018 Edition 7 ○ EN IEC 60079-11:2012 Edition 6 • UKEX (UK European legal directive) <ul style="list-style-type: none"> ○ BS EN IEC 60079-0:2018 Edition 7 ○ BS EN IEC 60079-11:2012 Edition 6
	RoHS	EN IEC 63000:2018
Serial Number and Year of Manufacture		Displayed on the side of the probe body or wrapped around the cable
<p>On behalf of the above-named company, I declare that, on the date the equipment accompanied by this declaration is placed on the market, the equipment conforms with all technical and regulatory requirements of the above listed directives and standards.</p> <p>Martin Jeffries – Quality Manager</p>		
		DATED: 02/10/2025 Larkfield



Operating Manual

Multi-Probe Oil/Grease Alarm (Mains)

Type PP/CAEx

Head Office

Darcy Group

Brook House,
Larkfield Trading Estate,
New Hythe Lane,
Larkfield, Kent
ME20 6GN

Manufacturing & Servicing

Darcy Spillcare

1 Hickmans Road
West Float
Wallasey
Cheshire
CH41 1JH

0800 0370 899 (UK)

+44 (0)1732 762338 (Rest of the World)

Aquasentry.uk

