

# AQUA SENTRY

## Operating Manual Universal Tank Alarm Type 14420B Installation, Operation & Maintenance



## Contents

Contents.....	1
Safety Symbols.....	1
Declaration of Conformity.....	2
General Function.....	3
General Operation.....	3
Applicable Firmware.....	4
Installation.....	4
Safety Instructions.....	4
<b>Special Conditions for Installation (X)</b> .....	5
Installing the Alarm.....	5
Probe Terminals.....	6
Beacon Terminals.....	6
Probe Cables.....	8
Mechanical.....	9
Beacon Output.....	9
Technical Information.....	9
Manufacturer.....	9
Models.....	9
14400B Alarm Specifications.....	10
PP/DGP-1 Capacitive FOG Probe Specifications.....	10
Input/Output Parameters.....	11
Accessories.....	11
Probe Types.....	11
Probe Cable.....	12
Beacon.....	12
Maintenance and Repair.....	12

**Separators and alarms should be serviced and maintained in accordance with BS EN 858-2**

## Safety Symbols





Safety instructions





Alarm is protected against shock hazard by double or reinforced insulation

## Declaration of Conformity

The above product meets all the essential safety requirements of the of the referenced UK Statutory Instruments and EU Directives listed below and is issued under the sole responsibility of the manufacturer.

<b>Equipment Name and Type</b>		<b>14400B Universal Tank Alarm</b>
Manufacturer		<b>Darcy Products Ltd. Brook House Larkfield Trading Estate New Hythe Lane Larkfield Kent ME20 6GN</b>
UK Legislation compliance		<b>S.I. 2016/1091</b> Electromagnetic Compatibility Regulations 2016  <b>S.I. 2016/1101</b> Electrical Equipment (Safety) Regulations 2016  <b>S.I. 2016/1107</b> Equipment and Protective Systems Intended for Use in Potentially Explosive Atmospheres Regulations 2016  <b>S.I. 2012/3032</b> The Restriction of the Use of Certain Hazardous Substances in Electrical and Electronic Equipment Regulations 2012
Certificate Number		CML 23UKEX2125
Specific Marking of Explosion Protection		 II (1) G [Ex ia Ga] IIB (-20°C ≤ Ta ≤ +50°C)
Approved Body Number		SGS United Kingdom Ltd. 1180
Standards Used	EMC	EN IEC 61326-1:2021 (Emissions Class B)
	LVD	EN 61010-1:2010/A1:2019
	UKEX	EN 60079-0:2018 EN 60079-11:2012
	RoHS	EN IEC 63000:2018
Serial Number and Year of Manufacture		Displayed on the side of the control unit
On behalf of the above-named company, I declare that, on the date the equipment accompanied by this declaration is placed on the market, the equipment conforms with all technical and regulatory requirements of the above listed directives and standards.		
Jurgen Fenney – Quality Manager		
		DATED: 14/06/2023 Larkfield

<b>Equipment Name and Type</b>		<b>14400B Universal Tank Alarm</b>
Manufacturer		<b>Darcy Products Ltd. Brook House Larkfield Trading Estate New Hythe Lane Larkfield Kent ME20 6GN</b>
Applicable European Directives:		2014/30/EU – Electromagnetic Compatibility Directive (EMC) 2014/35/EU – Low Voltage Directive (LVD) 2014/34/EU – Equipment for Potentially Explosive Atmospheres (ATEX) 2011/65/EU – Restriction of Hazardous Substances Directive (RoHS)
Certificate Number		CML 23ATEX2124
Specific Marking of Explosion Protection		 II (1) G [Ex ia Ga] IIB (-20°C ≤ Ta ≤ +50°C)
Notified Body Number		SGS Fimko Oy, Finland 0598
EU Harmonised Standards	EMC	EN IEC 61326-1:2013 (Emissions Class B)
	LVD	EN 61010-1:2010/A1:2019
	ATEX	EN 60079-0:2018 EN 60079-11:2012
	RoHS	EN IEC 63000:2018
Serial Number and Year of Manufacture		Displayed on the side of the control unit
On behalf of the above-named company, I declare that, on the date the equipment accompanied by this declaration is placed on the market, the equipment conforms with all technical and regulatory requirements of the above listed directives and standards.		
Jurgen Fenney – Quality Manager		
		DATED: 14/06/2023 Larkfield

## General Function

The unit is designed to monitor a tank for a build-up of oil or other liquid or monitor a grease trap for a build-up of fat, oil or grease. An alarm sounds and an LED beacon flashes when an alarm condition is detected. Two variants are available with different power capabilities, one mains powered, the other battery powered.

## General Operation

The unit can be configured in two modes, to monitor for a high level liquid using a conductivity probe or a float switch, or to monitor for fat, oil and grease in a grease trap using a capacitive probe. See jumper link settings for details of setting the desired mode.

When set to conductivity mode, the unit checks every second for the presence of oil at the probe by measuring conductivity, however a float switch probe may be used to detect a high liquid level. The probe is normally submersed in water and the LED on the unit will blink green every 5 seconds. When there is a sufficient build-up of oil at the surface that covers the conductivity probe, a sounder inside the unit sounds intermittently and the attached LED beacon flashes. The LED on the unit blinks red every 5 seconds. To silence the sounder and stop the LED beacon flashing, press



the button on the unit. The LED will remain red until the probe detects water once again, or the level drops if using a float switch probe.

When set to capacitive mode and a PP/DGP-1 Capacitive FOG Probe is used, the unit checks every 15 minutes for the presence of fat, oil, or grease (FOG) at the probe by measuring the capacitance of the liquid. Water has a much higher capacitance than FOG, so a build-up of FOG can be detected.

On the battery powered variant, a low battery is indicated by a double flash of the LED beacon.

## Applicable Firmware

Firmware ID	Description	Version
PP/FMW-1123	14400B Universal Tank Alarm	V1.01 or later

## Installation

**Note:** In all cases good, standard electrical practice should be followed, and the installation must conform to the appropriate local code of practice – e.g., BS EN 60079-25 in the UK. The installation must be such that the intrinsic safety is not compromised by: - exposure to risk of mechanical damage, unauthorised modification or interference, exposure to moisture, dust and foreign bodies, excessive heat, invasion of intrinsically safe circuit by other electrical equipment or circuitry.

Any deviation from this could invalidate the certification warranty and render the unit unsafe for its intended use. Please contact Darcy for any advice on 0800 0370 899.

The unit must be installed using a peak or similar cover to protect from direct sunlight.

## Safety Instructions

- ⚠ Installation should only be performed by a qualified electrician to local wiring regulations.
- ⚠ The type of cable to be used must suit the environment and the size of cable must be of a suitable size and current carrying capacity to suit the length of run and power consumption of the alarm, as per local wiring regulations. The cable must be protected by a suitable circuit breaker as per local wiring regulations. A 6A MCB and a minimum cable size of 1.0mm<sup>2</sup> is recommended.
- ⚠ The alarm is certified ATEX/UKEX/IECEX as Associated Apparatus and must only be installed in the safe area.
- ⚠ The conductivity probe and high level probe are Simple Apparatus and can be installed in the hazardous area.
- ⚠ The PP/DGP-1 Capacitive FOG Probe is ATEX/UKEX/IECEX certified and can be installed in the hazardous area.
- ⚠ Only a round section mains cable between 3mm and 6.5mm should be used to ensure a good seal is maintained in the cable gland.

- ⚠ Care must be taken that there are no loose wires strands which could come into contact with adjacent terminals. This is especially important between L and N terminals of J3. The use of bootlace ferrules is recommended to reduce the risk.
- ⚠ Cable glands supplied with the alarm are IP66 or better. Only use cable glands with at least an IP66 rating if replacing them for any reason.
- ⚠ Only use the mounting points shown in Figure 2. Do not drill holes in the enclosure or otherwise modify it as this would affect the IP65 rating and may allow water and/or moisture to enter the enclosure, affecting the correct function of the alarm and/or electrical safety, resulting in a potential electric shock hazard. It would also invalidate the ATEX/UKEX/IECEx certification.

### Special Conditions for Installation (X)

The equipment is not capable of withstanding the 500V insulation test required by Clause 6.3.12 of IEC/EN60079-11. This shall be taken into account when installing the equipment.

### Installing the Alarm

1. Choose a mounting position that will not be exposed to direct sunlight or use a peak or similar cover to prevent direct sunlight exposure.
2. Use the mounting points provided on the enclosure to mount in the position required. See Figure 2 for mounting points and dimensions.
3. For a float switch probe, hang the probe in the tank at the position which an alarm should occur.
4. For conductivity, immerse the probe in water. The depth of oil build up that will cause an alarm is chosen by the depth of the top electrode. An alarm occurs when the top electrode is covered by oil or is exposed to air.
5. For capacitive probe, immerse the probe in the grease trap or oil separator water. An alarm will occur when about the top 80% is FOG (Fat, Oil or Grease).
6. Wire the float, conductivity, or capacitive probe cable into J1 terminals on the PCBA inside the alarm according to Table 1.
7. If supplied, wire the beacon into J2 according to Table 2. Only use beacon type PP/BCN-1-2.
8. Set the jumper links according to the probe type being used. See Figure 4.
9. For the mains powered variant, wire a cable supplying 230VAC  $\pm 10\%$  50/60Hz to J3 on the PCBA inside the alarm.
  - a. A switch or circuit-breaker must be included in the installation.
  - b. It must be suitably located and easily reached.
  - c. It must be marked as the disconnecting device for the alarm.

10. Screw the lid back onto the enclosure base and ensure the 4 screws are tightened enough, but not overtight, that the rubber seal is compressed to maintain the IP65 seal.

## Probe Terminals

Probe Type	1	2	3
High Level (Float switch or conductivity)	Not connected	RED (or BROWN)	BLUE
PP/DGP-1 Capacitive FOG probe	BROWN	GREEN/YELLOW	BLUE

Table 1 – Probe cable connections (J1)

## Beacon Terminals

J2 Terminal	Connect To
+	Beacon positive terminal
-	Beacon negative terminal

Table 2 – Beacon cable connection details (J2)

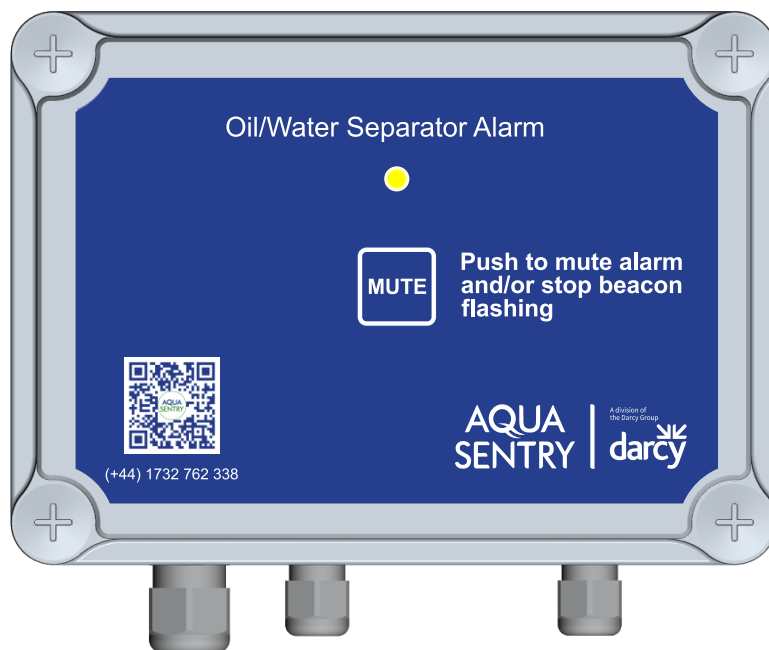

Figure 1 - External view of product

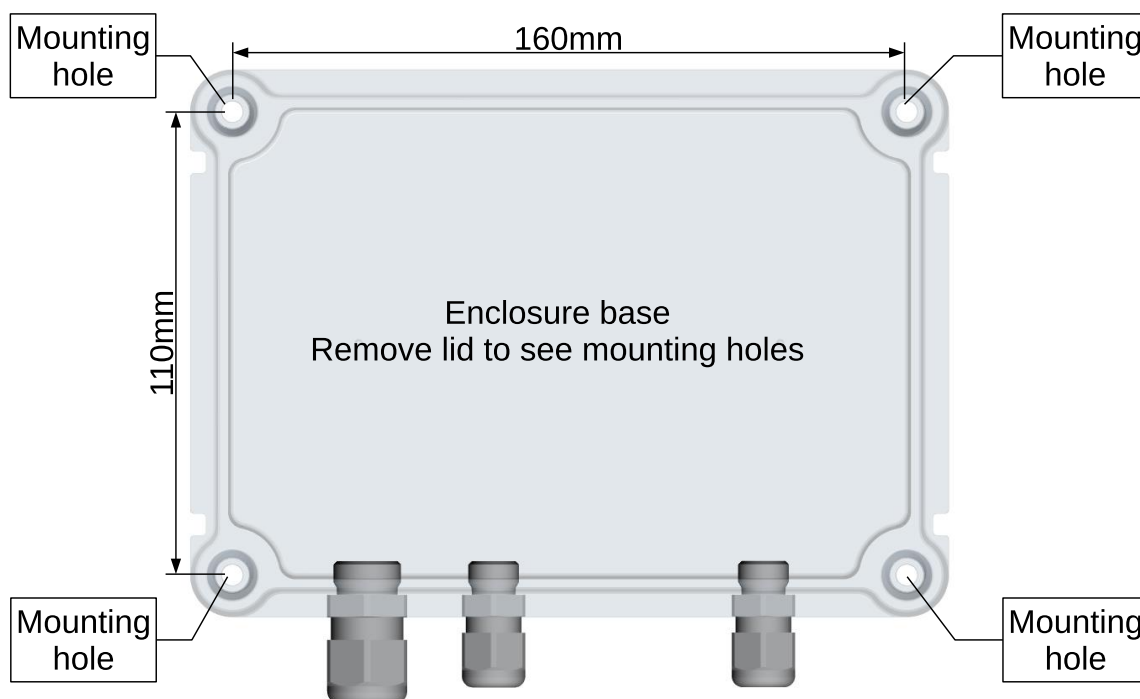

Figure 2 - Enclosure mounting hole positions



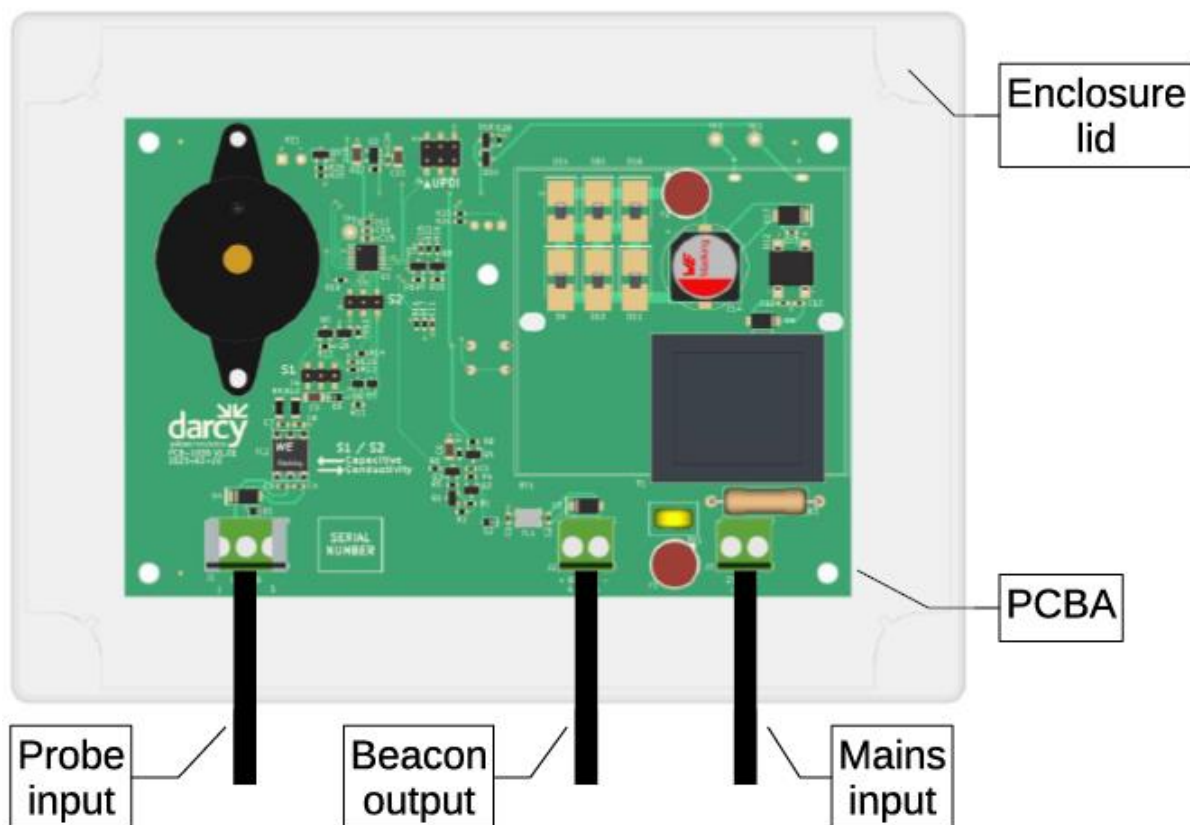

Figure 3 - Cable and terminal positions

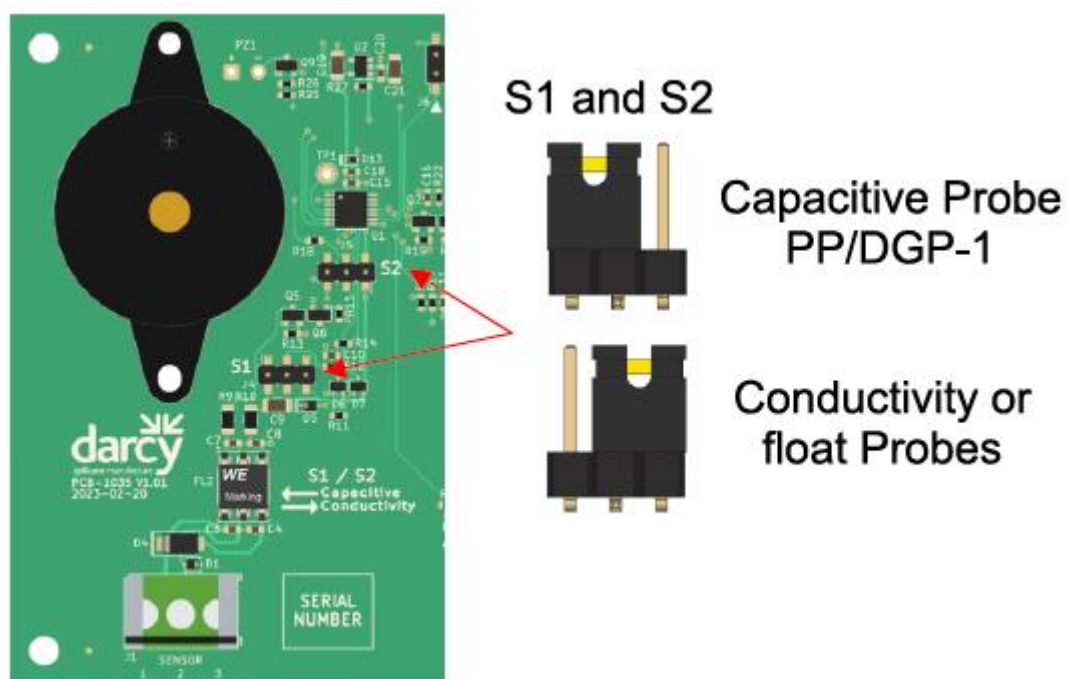

Figure 4 - Jumper link settings

### Probe Cables

The total capacitance and inductance of the cable used between the tank alarm unit and the probe must not exceed that shown in Table 4.

## Mechanical

Protection and/or screening of the cable should be considered when choosing a suitable cable. The maximum cable length between the probes and the tank alarm unit must not exceed 200 metres, or less if the values in Table 4 would be exceeded.

**The unit must be installed using a peak or similar cover to protect from direct sunlight.**

## Beacon Output

The beacon output, J2, must only be connected to LED beacon, PP/BCN-1-2. See notes below for restrictions on its use.

This output is activated when the probe detects an alarm condition, or a low battery for the battery powered variant. It is only deactivated again when the probe condition is changed to remove the probe alarm, or if the batteries are replaced for a low battery alarm on the battery powered variant.

### Notes on the beacon output:

- ⚠  $U_m = 0$ , i.e., no other source of power must ever be connected directly or indirectly to this output.
- ⚠ Must only be connected to a beacon which is powered entirely from this unit, i.e., this output must not be used as a control signal to a beacon that has its own power supply.
- ⚠ The beacon must be isolated from earth

## Technical Information

### Manufacturer

Darcy Products Ltd.  
 Brook House  
 Larkfield Trading Estate  
 New Hythe Lane  
 Larkfield  
 Kent  
 ME20 6GN  
 United Kingdom

Phone (UK): 0800 0370 899

Phone (Rest of the World): +44 (0) 1732 762338

[www.darcy.co.uk](http://www.darcy.co.uk)

### Models

Control Unit: 14400B Universal Tank Alarm.

Probe: PP/DGP-1 Capacitive FOG Probe.

See Accessories section for other probe types.

## 14400B Alarm Specifications

<b>Enclosure</b>	180mm(W) x 130mm(H) x 52mm(D) IP65 ABS	
<b>Operating environment</b>	Operating temperature: -20°C ... +50°C (ambient temperature) Do not allow direct exposure to sunlight Relative humidity: 100% Altitude: 2,000m Pollution degree: 2 Overvoltage category: CAT II Intended for use indoors or outdoors, and in wet locations	
<b>Mains supply voltage</b>	230VAC ±10%, 50/60Hz	
<b>Mains power consumption</b>	1.5W, 2.3VA, 0.01A, cos φ = 0.65	
<b>Electrical safety</b>	IEC/EN 61010-1:2010+A1:2019, Class II, CAT II	
<b>Battery type</b>	4 x AA (LR6) 1.5V alkaline cells	
<b>Battery runtime</b>	Using PP/DGP-1 Capacitive FOG Probe	
	No alarm	At least 2 years
	Probe alarm	At least 2 months
	Using conductivity or float switch probe	
	No alarm	At least 2 years
	Probe alarm	At least 2 months
<b>Galvanic isolation J3 to J1/J2</b>	Safe electrical isolation acc. to EN 60079-11, voltage peak value 358V	
<b>Max probe cable length</b>	200m (less if values in Table 4 would be exceeded)	
<b>Inputs</b>	1 x input from: Volt-free contacts (float switch) or Conductivity probes or PP/DGP-1 Capacitive FOG Probe Depending on setting of jumper links S1/S2 on PCBA.	
<b>Beacon output (J2)</b>	Unit mains powered: ≈ 6.8V, 37mA maximum Unit battery powered: ≈ 4V ... 6.4V, 37mA maximum Output current is limited to ≈ 37mA if short circuited	
<b>LED indicator</b>	Red/green LED. Normally green, red in alarm. Flashes intermittently on battery power to save power. Double flashes to indicate a low battery.	

## PP/DGP-1 Capacitive FOG Probe Specifications

<b>Enclosure</b>	85.5mm(L) x 30mm(Dia) IP68
<b>Material</b>	S303, plastic
<b>Cable</b>	Fixed 3-core 0.5mm <sup>2</sup> . Length 5m. Can be extended externally to 30m.
<b>Weight</b>	390g (including 5m cable)
<b>Operating temperature</b>	0°C ... +50°C (ambient temperature) Do not allow direct exposure to sunlight

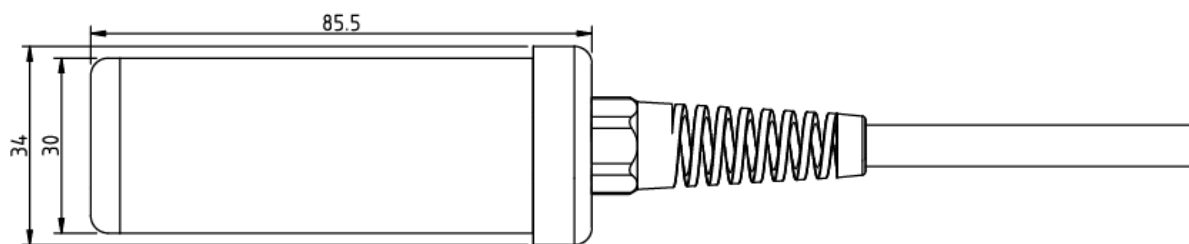

Figure 5 - PP/DGP-1 Capacitive FOG Probe Dimensions

## Input/Output Parameters

<b>Mains Powered Variant</b>	<b>U<sub>o</sub></b>	8.19V
	<b>I<sub>o</sub></b>	108mA
	<b>P<sub>o</sub></b>	221mW
	<b>C<sub>i</sub></b>	0
<b>Battery Powered Variant</b>	<b>L<sub>i</sub></b>	60μH
	<b>U<sub>o</sub></b>	6.6V
	<b>I<sub>o</sub></b>	87mA
	<b>P<sub>o</sub></b>	118mW
	<b>C<sub>i</sub></b>	0
	<b>L<sub>i</sub></b>	60μH

Table 3 – Hazardous area terminals (J1)

	<b>Group</b>	<b>Capacitance (μF)</b>	<b>Inductance (mH)</b>	<b>OR</b>	<b>L/R Ratio (μH/Ω)</b>
Mains Powered Variant	IIB	81	12.13		643
	IIA	1000	24.33		1286
Battery Powered Variant	IIB	500	18.73		991
	IIA	1000	37.52		1982

Table 4 – J1 load parameters

## Accessories

### Probe Types

These probes are suitable for use with the alarm.

<b>Part Number</b>	<b>Type</b>	<b>Use</b>
PP/14011	High level float switch	Detection of a high liquid level in a tank or oil separator
PP/14200	38mm Conductivity Probe	Detection of oil build up in a tank
PP/14201	25mm Conductivity Probe	Detection of oil build up in a tank
PP/14205	12mm Conductivity Probe	Detection of oil build up in a tank
PP/DGP-1	Capacitive FOG Probe	Detection of fat, oil or grease in a grease trap

## Probe Cable

Whilst many different cables can be suitable for use with the probe, some customers feel more comfortable with some guidance. A typical example of a suitable cable is shown in Table 5. It can be ordered from Darcy or from Farnell (<http://www.farnell.com>) as order code 1503980.

<b>Manufacturer</b>	Lapp Kabel
<b>Manufacturer Part No.</b>	0012640
<b>Inductance</b>	0.65mH/km
<b>Capacitance</b>	Core-core : approx. 135nF/km
	Core-screen : approx. 185nF/km

Table 5 – Typical probe cable

## Beacon

A suitable 6V LED beacon can be ordered from Darcy as PP/BCN-1-2.

## Maintenance and Repair

For all repairs, contact Darcy Spillcare Manufacture on 0800 0370 899.

Darcy Spillcare Manufacture  
1 Hickmans Road  
Wallasey  
Birkenhead  
CH41 1JH  
United Kingdom





# Operating Manual

## Universal Tank Alarm

### Type 14420B

#### Head Office

Darcy Group  
Brook House  
Larkfield Trading Estate  
New Hythe Lane  
Larkfield, Kent  
ME20 6GN

#### Manufacturing & Servicing

Darcy Spillcare  
1 Hickmans Road  
West Float  
Wallasey  
CH41 1JH

0800 0370 899  
+44 (0)1732 762338  
Aquasentry.uk

