



Product Summary

The High Level Liquid Probe is designed to monitor for excessive liquid levels within tanks, separators, wash-down units or cesspools.

The sensor uses a simple float switch design, which when triggered, will send an alarm signal back to the control panel.

Benefits

- > Simple apparatus
- > 5 metres of cable
- > Can be retro-fitted to most applications
- > Level float switch operation
- > Flexible strain relief cable gland.

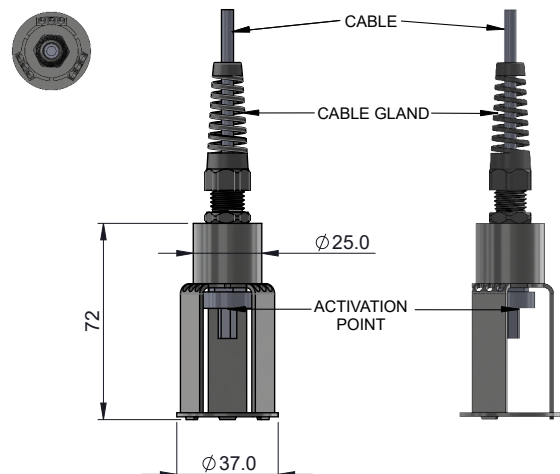

Specifications

Model	PP/Probe/HLQD-1
Dimensions	72mm x 37mm
Material	316 Stainless Steel, Polypropylene
ATEX Classification	Simple Apparatus (See letter of confirmation)
Cable	2 Core – 0.25mm. Length 5m. Can be extended externally to 200m.
Weight	280g (including 5m cable)
Operating Temperature	-20°C ... 50°C (ambient temperature)

Email: sales@darcy.co.uk

Call: 0800 0370 899 or +44 (0)1732 762338